

TWN4 MultiTech SmartCard

TWN4 SmartCard MIFARE NFC USB

Multi-frequency RFID reader (LF/HF/NFC) for ISO/IEC 7816 cards



TWN4 MultiTech SmartCard
(exemplary illustration)

ELATEC TWN4 MultiTech SmartCard is a combination of the TWN4 MultiTech (RFID) and an integrated contact card reader/writer (ISO 7816). It allows users to read and write to almost any 125 kHz and 13.56 MHz tags and/or labels. It supports all major technologies from various suppliers like ATMEL, EM, ST, NXP, TI, HID, LEGIC, etc. and many ISO standards like ISO 14443A/B (T=CL), ISO 15693 and ISO 18092 / ECMA-340 (NFC). The integrated chip card reader has been designed for easy integration into various applications.

The reader can be programmed with a script language for autonomous execution of even complex commands like login procedures, increment/decrement functions and many more. The reader supports host communication via USB or RS-232.

Special features:

- + Powerful SDK for writing apps which are executed directly on the reader
- + Firmware update in the field possible
- + On-board 18 kB flash storage, e.g. for storing user accessible non-volatile data
- + Supports transparent data exchange with RFID media
- + CCID and PC/SC 2.01



Elevator



EV Chargers



Access



Shop POS



Fitness
Equipment



Ticket POS



PC Log-on



Document
Management



Driver ID



Vending



Parking



Gaming



Locker Locks



Time
Attendance



Industrial
PC

TECHNICAL DATA

FREQUENCIES	125 kHz (LF) / 13.56 MHz (HF)
ANTENNAS	Integrated
HOUSING	Material: ABS UL94-V0 Color: black or white
DIMENSIONS (L X W X H)	Approx. 88.00 x 68.00 x 19.19 mm / 3.46 x 2.68 x 0.76 inch
POWER	USB: 4.3 V – 5.5 V RS-232: requires 5 V external power supply ES1/PS2 classified power source according to IEC 62368-1, short-circuit current < 8 A
TEMPERATURE RANGE	Operating: -25 °C up to +70 °C (-13 °F up to +158 °F) Storage: -40 °C up to +75 °C (-40 °F up to +167 °F)
RELATIVE HUMIDITY	5% to 95% non-condensing
READ/WRITE DISTANCE	LF and HF: up to 100 mm / 4 inch, depending on environment and transponder
OPERATING MODES (USB)	USB keyboard emulation – USB virtual COM port – CCID / PC/SC 2.01
MTBF	500,000 hours / Min. 100,000 card insertion cycles
WEIGHT	Approx. 140 g / 4.94 oz (with housing and USB cable)
SMARTCARD STANDARDS	ISO/IEC 7816 Part 1-4, Class A/B/C (5V, 3V, 1.8V), T=0, T=1
SMARTCARD CLOCK FREQUENCY	5 MHz up to 15 MHz
SUPPORTED SMARTCARDS	5V, 3V and 1.8V, ISO/IEC 7816 Class A/B/C
POWER TO SMARTCARD	60 mA in Class A; 55 mA in Class B; 35 mA in Class C
SMARTCARD DETECTION	Card present switch / Automatic power on/off / Short-circuit protection
SMARTCARD CARD SIZE	2x ID-000 (SAM) ID-1
SMARTCARD CONTACT TYPE	8-pin sliding contact socket, C4/C8 support ID-1
SUPPORTED OPTIONS AND TRANSPONDERS	Depending on the firmware version and installed options, ELATEC readers and modules can support a wide range of RFID technologies. Please refer to the relevant ELATEC transponder matrix (available at www.elatec-rfid.com/int/transponder-technology) for more information about the available options and RFID technologies supported by the product.
OS SUPPORT	Windows 7 (32-/64-bit) and higher versions, Linux, Android ¹⁾ , iOS ¹⁾ , MAC OS X ¹⁾
PERIPHERAL INTERFACES	USB, RS-232, 2 SAM slots
TRANSMISSION SPEED	Host: USB full speed (12 Mbit/s), RS-232: up to 115,200 baud, HF Air: up to 848 kbit/s
CERTIFICATION NAME	TWN4 SmartCard MIFARE NFC USB
CERTIFICATIONS	Non-exhaustive list ²⁾ : CE/RED, FCC, IC, TAA compliant, REACH and RoHS-III compliant
ORDER CODES	T4SD-FB2BE1 Standard reader, USB cable, black housing T4SD-FB2WE1 Standard reader, USB cable, white housing T4SD-FB2BE1-P Reader with P option, USB cable, black housing T4SD-FB2WE1-P Reader with P option, USB cable, white housing T4SD-FB2BE1-PI Reader with PI options, USB cable, black housing T4SD-FB2WE1-PI Reader with PI options, USB cable, white housing The order codes above describe readers equipped with a two-meter-long cable. Contact ELATEC for other cable lengths.

¹⁾On request

²⁾The product has been certified for use in many countries and regions. Contact your Sales representative for detailed information about all certifications and approvals granted to the product.

ACCESSORIES

HOLDERS	HKSD-B	SmartCard holder kit, black
	HKSD-W	SmartCard holder kit, white
POWER SUPPLIES	ELATEC RFID readers and modules can be delivered with additional cables or external power supplies. Refer to the data sheet <i>Cables for ELATEC devices</i> for detailed information.	

TECHNICAL DRAWINGS

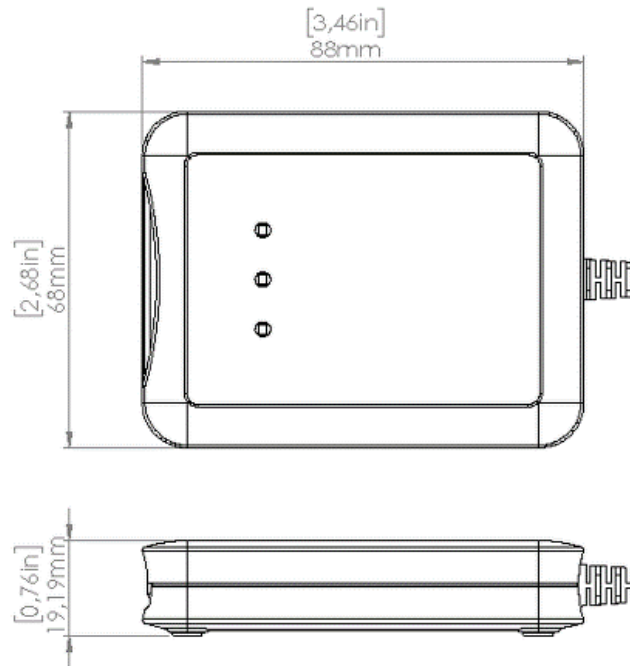

ELATEC GmbH

Zeppelinstr. 1
82178 Puchheim
Germany
P +49 89 552 9961 0
F +49 89 552 9961 129
E-Mail: info-rfid@elatec.com
Website: elatec.com

ELATEC Systems GmbH

Schwieberdinger Str. 44
71636 Ludwigsburg
Germany
P +49 7141 309736 0
E-Mail: info-rfid@elatec.com
Website: elatec.com

ELATEC Inc.

1995 SW Martin Hwy
Palm City • FL 34990
USA
P +1 772 210 2263
F +1 772 382 3749
E-Mail: americas-info@elatec.com
Website: elatec.com

ELATEC Technology (Shenzhen) LLC

918, Main Building, Tian An Cyber Times
Tower, No. 6, Tairan Fourth Road, Tian 'an
Community, Shatou Neighborhood
Futian District • Shenzhen • China
P/F +86 755 2394 6014
E-Mail: apac-info@elatec.com
Website: elatec.com

ELATEC reserves the right to change any information or data in this document without prior notice. ELATEC declines all responsibility for the use of this product with any other specification but the one mentioned above. Any additional requirement for a specific customer application has to be validated by the customer themselves at their own responsibility. Where application information is given, it is only advisory and does not form part of the specification. Disclaimer: All names used in this document are registered trademarks of their respective owners.